

A tunable and dispersion-insensitive microwave photonic filter

ZHANG YaMei & PAN ShiLong*

Microwave Photonics Research Laboratory, College of Electronic and Information Engineering Nanjing University of Aeronautics and Astronautics, Nanjing 210016, China

Received November 7, 2012; accepted January 5, 2013; published online January 14, 2013

A tunable and dispersion-insensitive two-tap microwave photonic filter (MPF) with a complex coefficient is proposed and demonstrated. By simply adjusting a polarization controller (PC) in one tap, the filter can be tuned over the entire free spectral range (FSR) while keeping the shape of the filter unchanged. Because the two taps are both single-sideband (SSB) modulated, the filter has high tolerance to fiber dispersion. The transmission response of a system with 25- or 40-km single-mode fiber (SMF) was measured and compared with an MPF with one double sideband (DSB) modulation tap. The proposed MPF shows much better performance for long-distance fiber transmission.

microwave photonic filter, single sideband modulation, microwave photonics

Citation: Zhang Y M, Pan S L. A tunable and dispersion-insensitive microwave photonic filter. *Sci China Tech Sci*, 2013, 56: 603–607, doi: 10.1007/s11431-013-5136-2

1 Introduction

Microwave photonic filter (MPF) has attracted great interests in processing microwave or millimeter wave signals in the optical field due to the inherent characteristics brought by the photonic technologies, such as broad bandwidth, low loss, light weight, and immunity to electromagnetic interference [1–3]. Previously, a great number of methods have been explored to implement MPFs with positive, negative or complex coefficients [1–3]. Among the three different kinds of MPFs, the one with complex coefficients is most attractive because the center frequency can be tuned without changing the shape of the filter [1–3]. Generally, the complex coefficient tap in an MPF is implemented by a photonic microwave phase shifter. To realize the microwave phase shifter photonically, the slow light is considered as an excellent approach [4–7], which is induced by the stimulated Brillouin scattering in optical fiber, coherent population

oscillation in semiconductor optical amplifiers or steep filtering in optical resonators. Some tunable MPFs were also reported based on this type of photonic microwave phase shifter [8–10]. This technique, however, suffers severely from the limited operational bandwidth, strict control of the optical powers and wavelengths, or difficulties in tuning the filter over the entire free spectral range (FSR). To realize the full-FSR tunability, some other configurations based on dual-parallel Mach-Zehnder modulator (MZM), optical differentiator or programmable elements have been proposed [11–13]. But these systems have other limitations such as large insertion loss, bias drifting problem [11], complicated control of wavelength and amplitude of the laser source [12], or phase and amplitude responses of the filter [13]. In addition, the signal after filtering is always not suitable for fiber transmission because most of the MPFs are based on double sideband (DSB) modulation and DSB signals would undergo serious distortion in a dispersive medium. Because the photonic microwave signal processing is always accompanied by fiber distribution of the processed signals to a remote site, it is highly desirable to construct a tunable MPF

*Corresponding author (email: pans@iee.org)

that is dispersion-insensitive. Recently, we have proposed a novel photonic microwave phase shifter using a polarization modulator (PolM), an optical bandpass filter (OBPF) and a polarizer [14]. This novel phase shifter features wideband operation, continuously tunable phase shift from -180° to 180° , large tuning speed and compact configuration. With the phase shifter incorporated to one tap, a two-tap MPF was realized¹⁾. The center frequency of the filter can be tuned over the entire FSR while keeping the shape of the filter unchanged. But the MPF is also based on DSB modulation, so the signal after filtering would undergo dispersion-induced power penalty when transmitted in an optical fiber.

In this letter, we propose and experimentally demonstrate a novel dispersion-insensitive two-tap MPF with a complex coefficient. The filter can be tuned over the entire FSR without changing the shape of the filter. Because the signal after filtering is intrinsically single sideband (SSB), the system is free from dispersion induced power penalty.

2 Principle

Figure 1 shows the schematic diagram of the proposed MPF, which consists of two taps implemented in two arms. In the upper arm, there is a laser source, a PolM, a polarization controller (PC), a polarizer and an OBPF. The PolM is a special phase modulator that can support both TE and TM modes with opposite phase modulation indices. When a linearly polarized incident lightwave from a laser source oriented at an angle of 45° to one principal axis of the PolM is launched to the PolM, two complementary phase-modulated signals are generated along the two principal axes. The two orthogonally polarized signals are subsequently combined at a polarizer. A PC is inserted between the PolM and the polarizer to align the angle between the principal axis of

the polarizer and one principal axis of the PolM. Mathematically, if the electrical signal applied to the PolM is $\cos\omega_m t$, the output signal from the polarizer can be written as

$$E_{\text{out}}(t) = \cos\alpha \exp(j\omega_0 t + j\varphi)[J_0(\gamma) + jJ_1(\gamma)\exp(j\omega_m t) - jJ_{-1}(\gamma)\exp(-j\omega_m t)] + \sin\alpha \exp(j\omega_0 t)[J_0(\gamma) - jJ_1(\gamma)\exp(j\omega_m t) + jJ_{-1}(\gamma)\exp(-j\omega_m t)], \quad (1)$$

where ω_0 is the angular frequency of the optical carrier, γ is the phase modulation index, φ is the phase difference between the signals along the two principal polarization axes which is controlled by the DC bias of the PolM, J_n is the Bessel function of the first kind of order n , and α is the angle between the principal axis of the polarizer and one principal axis of the PolM. In eq. (1), small-signal modulation is assumed, so the higher-order (≥ 2) sidebands are ignored.

In the lower arm, a linearly polarized light generated by a second laser source is intensity-modulated at an MZM biased at the quadrature point. When the modulating signal is the same as that applied to the PolM, the output signal can be expressed as

$$E_{\text{out-MZM}}(t) = \exp(j\omega_c t)[J_0(\beta) + J_1(\beta)\exp(j\omega_m t) + J_{-1}(\beta)\exp(-j\omega_m t)], \quad (2)$$

where ω_c is the angular frequency of the optical carrier of the second laser source, and β is the modulation index of the MZM. Then, the signals in eqs. (1) and (2) are incoherently combined by a 50:50 coupler, and sent to an OBPF with two steep edges. The wavelengths of the two laser sources are set to be located at the left and right edges, respectively. Because the edges are very steep, the +1st-order sideband in eq. (1) and -1st-order sideband in eq. (2) are effectively removed. The combined signal is given by

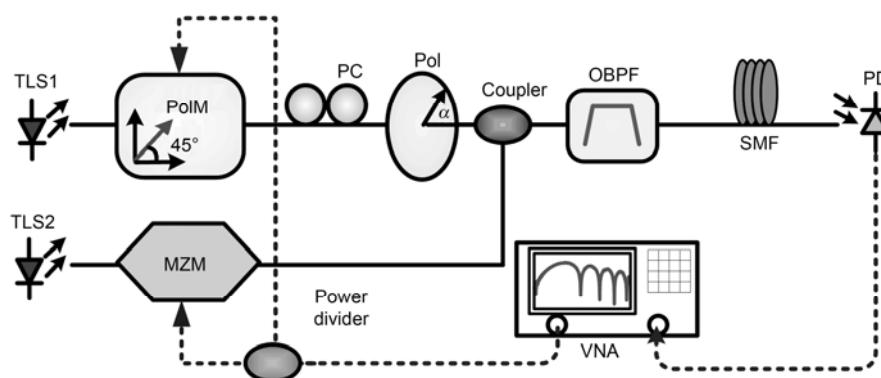

Figure 1 The schematic of the proposed microwave photonic filter. TLS: tunable laser source; PC: polarization controller; PolM: polarization modulator; SMF: single mode fiber; PBS polarization beam splitter; PD: photodetector; VNA: vector network analyzer; MZM: Mach-Zehnder modulator.

1) Zhang Y M, Pan S L. A complex coefficient microwave photonic filter using a polarization-modulator-based phase shifter. IEEE Photon Technol Lett, accepted

$$E_{out}(t) = \exp[j\omega_c(t + \tau)]\{J_0(\beta) + J_1(\beta)\exp[j\omega_m(t + \tau)]\} + \cos\alpha \exp(j\omega_0 t + j\varphi)[J_0(\gamma) - jJ_{-1}(\gamma)\exp(-j\omega_m t)] + \sin\alpha \exp(j\omega_0 t)[J_0(\gamma) + jJ_{-1}(\gamma)\exp(-j\omega_m t)], \quad (3)$$

where τ is the time delay between the two arms.

If the signal in eq. (3) is sent to the PD for square-law detection and let $\varphi = \pi/2$ by adjusting the DC bias of the PolM, the AC term of the current can be written as

$$I(t) \propto J_0(\beta)J_1(\beta)\cos[\omega_m(t + \tau)] + \cos\left(\omega_m t + 2\alpha + \frac{\pi}{2}\right)J_0(\gamma)J_{-1}(\gamma). \quad (4)$$

By controlling the microwave power, we can make $\beta = \gamma$. Representing eq. (4) in the complex exponential form, we obtain

$$I(t) \propto e^{j\omega_m t} \left[e^{j\omega_m \tau} + e^{j(2\alpha + \pi/2)} \right] = \cos(\omega_m \tau / 2 - \alpha - \pi / 4) e^{j(\omega_m t + \omega_m \tau / 2 + \alpha + \pi / 4)}. \quad (5)$$

The transfer function of the entire system can be given by

$$H(\omega) = \cos(\omega \tau / 2 - \alpha - \pi / 4) e^{j(\omega \tau / 2 + \alpha + \pi / 4)}. \quad (6)$$

As can be seen from (6), the FSR is $2\pi/\tau$, and the peak frequency is $(2k\pi + 2\alpha + \pi/2)/\tau$. If α is tuned in the range of $[0, \pi]$, which can be implemented by adjusting the PC between the PolM and the polarizer, the center frequency can be changed in the full FSR. Because the FSR is governed by τ , the tuning of the center frequency does not affect the shape of the filter. Because the change of α does not affect the magnitude of the filter, the tuning of the center frequency will not introduce any variation to the peak transmittance of the filter. In addition, the signal after filtering is an SSB signal, so it would have high tolerance to fiber dispersion.

3 Experiment results and discussion

An experiment based on the schematic diagram shown in Figure 1 was carried out. A multi-channel tunable laser source (Agilent N7714A) was used to provide the two wavelengths in the two arms. The wavelengths were 1551.140 and 1550.140 nm, respectively. The PolM (Ver-sawave Inc.) has a bandwidth of 40 GHz and a half-wave voltage of 3.5 V. The MZM with a bandwidth of 40 GHz and a half-wave voltage of 3.1 V was biased at the quadrature point. The OBPF (Yenista XTM-50) has two steep edges of more than 500 dB/nm. An RF signal generated by a 50-GHz vector network analyzer (VNA, Agilent N5245A) with a power of 10 dBm was split by an RF power divider,

and applied to the PolM and MZM, respectively. A PD with a 3-dB bandwidth of 40 GHz and a responsivity of 0.65 A/W is used for optical to electrical conversion. The frequency response of the entire system was measured by the VNA.

Figure 2 shows the transmission response of the OBPF, and the optical spectra before and after the OBPF. As can be seen, the +1st and higher order sidebands of the polarization-modulated signals and the -1st and lower order sidebands of the intensity-modulated signals are suppressed by more than 55 dB. As a result, both signals are with SSB modulation.

Figure 3 shows the frequency response of the photonic filter. The FSR is 22.5 MHz, corresponding to about 8.9-m optical fiber length difference between the two arms. If a tunable optical delay line is used in the system, the FSR can be adjusted. By simply adjusting the PC, the center frequency of the filter can be tuned over the entire FSR while keeping the shape of the filter unchanged. In addition, more than 50-dB rejection ratio is obtained over the tuning process. Because the filter is tuned by a PC and the state-of-the-art electrical polarization converter can reach a tuning

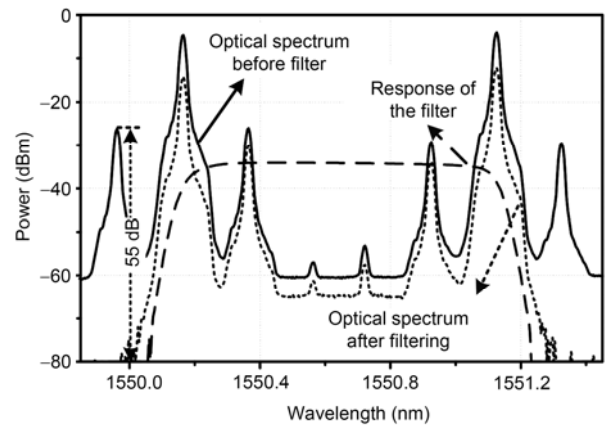

Figure 2 The optical spectra of the signals before and after the OBPF, and the transmission response of the OBPF.

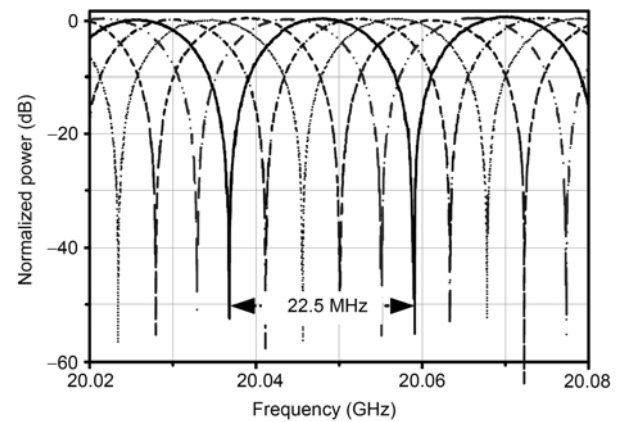

Figure 3 The measured frequency response of the proposed filter.

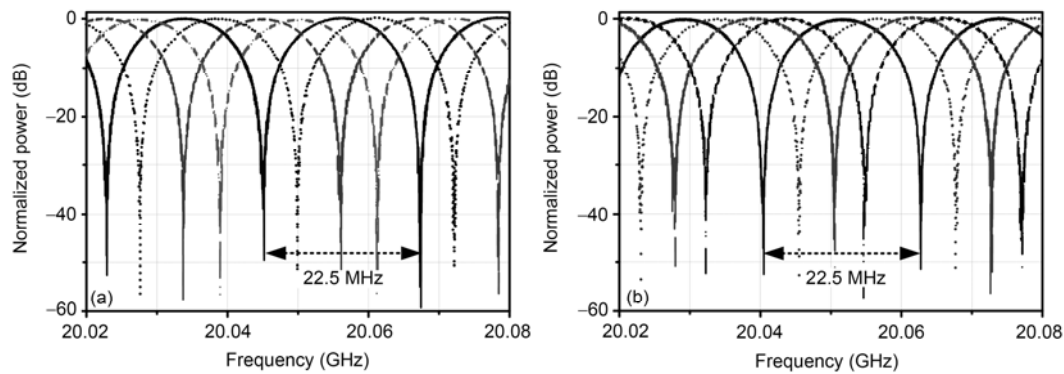

Figure 4 Frequency responses of the proposed MPF with (a) 25-km SMF transmission and (b) 40-km SMF transmission.

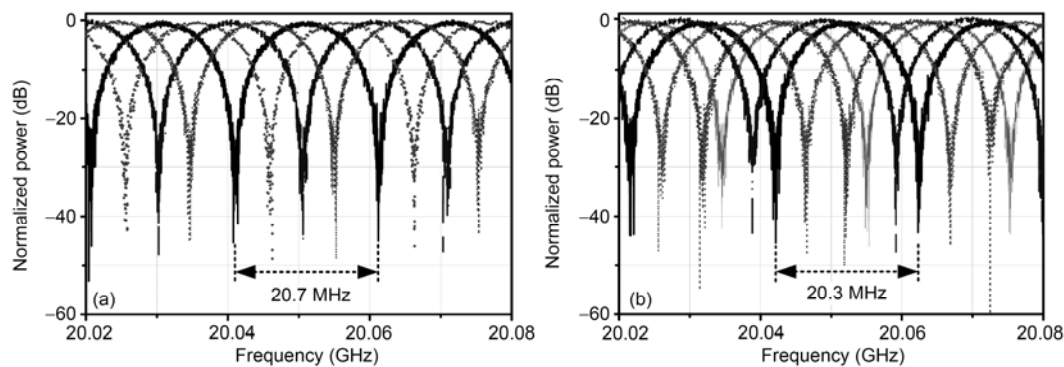

Figure 5 Frequency responses of the MPF with one DSB tap and (a) 25-km SMF transmission and (b) 40-km SMF transmission.

speed of more than 40 GHz [15], the proposed microwave photonic filter is suitable for ultra-high-speed photonic microwave signal processing. In addition, the microwave photonic filter is possibly multi-octave tunable, since the photonic microwave phase shifter can operate over 11–43 GHz[14].

Because the signal after filtering is an SSB signal, the MPF should have high tolerance to the fiber dispersion. To verify this, we connected a section of single-mode fiber (SMF) with a length of 25 or 40 km between the OBPF and the PD. Figure 4 shows the frequency responses of the MPF with fiber transmission. As can be seen, the frequency responses of the MPF with long fiber transmission have no evident difference with the one without fiber transmission. The FSR is still 22.5 MHz, and no obvious dispersion-induced power penalty is observed. In addition, the notch depths are still larger than 50 dB. As a comparison, we move the optical coupler to pass the OBPF. Because the intensity-modulated signal does not pass through the OBPF, it has two sidebands. Figure 5 shows the frequency responses of the MPF with one DSB tap. With the 25-km SMF and 40-km SMF fiber transmission, the frequency responses have large noise because of the dispersion-induced power penalty. At the same time, the FSR of the two frequency responses are different, i.e., 20.7 MHz for the 25-km SMF transmission and 20.3 MHz for the 40-km

SMF transmission. The comparison adequately demonstrates that the proposed MPF has superior performance for long-distance fiber transmission.

4 Conclusion

A tunable and dispersion-insensitive MPF operated in the 11–43 GHz band was proposed and experimentally demonstrated. The center frequency of the MPF could be tuned over the entire FSR by simply adjusting a PC. More than 50-dB rejection ratio was obtained. The signal after filtering is intrinsically single sideband (SSB), so the system is suitable for long-distance fiber transmission. The frequency response of the MPF with 25-km and 40-km SMF showed no evident difference with that without SMF. The multi-octave tunable filter may find applications in ultra-high-speed photonic microwave signal processing.

This work was supported in part by the National Natural Science Foundation of China (Grant No. 61107063), the National Basic Research Program of China (Grant No. 2012CB315705), the Jiangsu Provincial Funds for Distinguished Young Scientists (Grant No. BK2012031), the Fok Ying Tung Education Foundation, the National Aerospace Science Foundation of China (Grant No. 2012ZD52052), the Fundamental Research Funds for the Central Universities (Grant No. NE2012002), and the Project Funded

by the Priority Academic Program Development of Jiangsu Higher Education Institutions.

- 1 Minasian R A. Photonic signal processing of microwave signals. *IEEE Trans Microw Theory Tech*, 2006, 54(2): 832–846
- 2 Yao J P. Microwave Photonics. *J Lightw Technol*, 2009, 27(3): 314–335
- 3 Capmany J, Ortega B, Pastor D. A tutorial on microwave photonic filters. *J Lightw Technol*, 2006, 24(1): 201–229
- 4 Pu M H, Liu L, Xue W Q, et al. Tunable microwave phase shifter based on silicon-on-insulator microring resonator. *IEEE Photon Technol Lett*, 2010, 22(12): 869–871
- 5 Sancho J, Lloret J, Gasulla I, et al. 2π microwave photonic phase shifter based on single semiconductor optical amplifier. *Proceeding of the 2011 IEEE MWP*, 2011
- 6 Chang Q, Li Q, Zhang Z, et al. A tunable broadband photonic RF phase shifter based on a silicon micro-ring resonator. *IEEE Photon Technol Lett*, 2009, 21(1): 60–62
- 7 Loayssa A, Lahoz F J. Broad-band RF photonic phase shifter based on stimulated Brillouin scattering and single-sideband modulation. *IEEE Photon Technol Lett*, 2006, 18(1): 208–210
- 8 Loayssa A, Capmany J, Sagues M, et al. Demonstration of incoherent microwave photonic filters with all-optical complex coefficients. *IEEE Photon Technol Lett*, 2006, 18(16): 1744–1746
- 9 Sagues M, Loayssa A. Orthogonally polarized optical single sideband modulation for microwave photonics processing using stimulated Brillouin scattering. *Opt Express*, 2010, 18(22): 22906–22914
- 10 Xue W Q, Sales S, Mork J, et al. Widely tunable microwave photonic notch filter based on slow and fast light effects. *IEEE Photon Technol Lett*, 2009, 21(3): 167–169
- 11 Li W, Zhu N H, Wang L X. Continuously tunable microwave photonic notch filter with a complex coefficient. *IEEE Photon Technol Lett*, 2011, 3(3): 462–467
- 12 Yi X K, Huang T X H, Minasian R A. Tunable and reconfigurable photonic signal processor with programmable all-optical complex coefficients. *IEEE Trans Microw Theory Tech*, 2010, 58(11): 3088–3093
- 13 Li X, Dong J J, Yu Y, et al. A tunable microwave photonic filter based on an all-optical differentiator. *IEEE Photon Technol Lett*, 2011, 25(3): 308–310
- 14 Pan S L, Zhang Y M. A tunable and wideband microwave photonic phase shifter based on a single sideband polarization modulator and a polarizer. *Opt Lett*, 2012, 37(21): 4483–4485
- 15 Bull J D, Jaeger N A F, Kato H, et al. 40 GHz electro-optic polarization modulator for fiber optic communications systems. *Proc SPIE*, 2004, 5577: 133–143